

Project:	
Type:	
Catalog #:	



## ILLUMINATION

- Long lasting, efficient ultra bright white LED lamp heads.
- 1.7 watt (8 LEDs x 0.2125) per head.
- High performance chrome-plated metallized reflector and plastic lens for optimal light distribution.
- Adjustable LED lamp heads provides optimal center-to-center spacing.

## ELECTRICAL

- Dual 120/277 voltage standard.
- Charge rate/power “ON” LED indicator light and push-to-test switch for mandated code compliance testing.
- 3.6V long life, maintenance-free, rechargeable NiCd battery.
- Internal solid-state transfer switch automatically connects the internal battery to LED lamp heads for minimum 90-minute emergency illumination.
- Fully automatic solid-state, two rate charger initiates battery charging to recharge a discharged battery in 24 hours.

## MOUNTING

- Universal knockout pattern on back plate for surface mount. Snaps into place making internal electrical connections.
- Suitable for wall or ceiling mount.
- Knockout for conduit applications.

## HOUSING

- Injection-molded, engineering grade, 5VA flame retardant, high-impact resistant, thermoplastic in white or black finish.

## WARRANTY / LISTING

- Five year warranty on all electronics and housing. Battery prorated for five years.
- UL Listed for damp locations. (0°C – 50°C)
- Meets UL924, NFPA 101 Life Safety Code, NEC, OSHA, Local and State Codes.

## DIMENSIONS

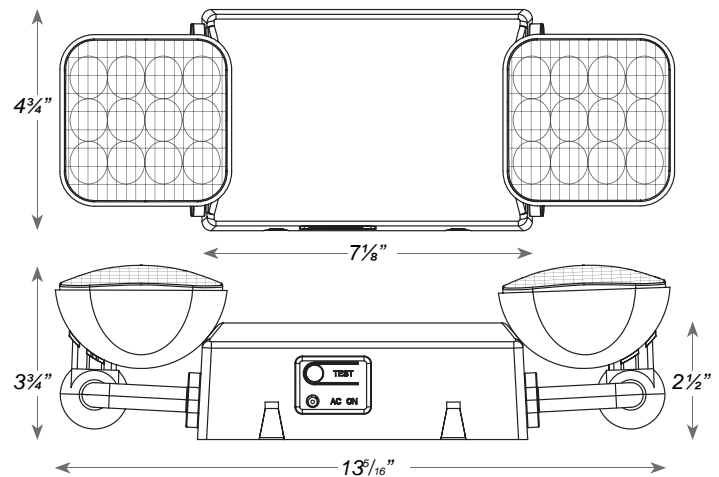

## ORDERING INFORMATION

MODEL	HOUSING COLOR	
ARI-EM	WH	White
	BK	Black